

RÖSCHERMATIC - Typ OSNAVAC 4

RÖSCHERMATIC - Type OSNAVAC 4

Kammermaß:	340x425x140 mm
nutzbares Kammermaß:	325x375x140 mm
Schweißschienenlänge:	325 mm
Außenabmessung:	400x660x310 mm
Gewicht:	49 kg
Stromanschluß:	230 V, 50 Hz, 1 Phase
Anschlußwert:	0,7 kW
<small>Kabel 3 m lang mit Schuko-Winkelstecker</small>	
Sonderausstattung:	Trenndrahtschweißung Sonderspannungen

chamber dimensions:	340x425x140 mm
effective chamber dimensions:	325x375x140 mm
length of sealing bar:	325 mm
external dimensions:	400x660x310 mm
net weight:	49 kg
voltage:	230 V, 50 cycles, 1 phase
connected load:	0,7 kW
<small>cable of 3 m length with shock-proof angle plug</small>	
Special Outfit:	cut off wire special voltages

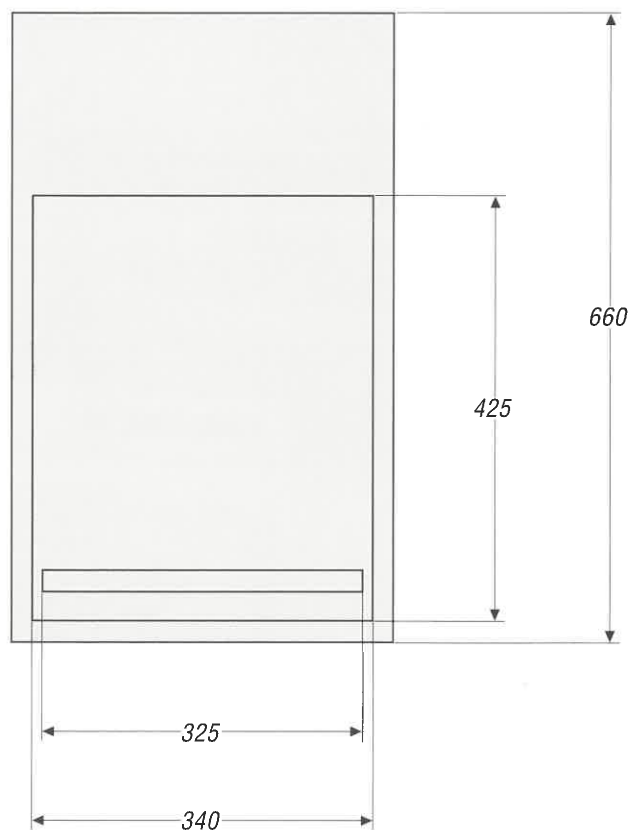
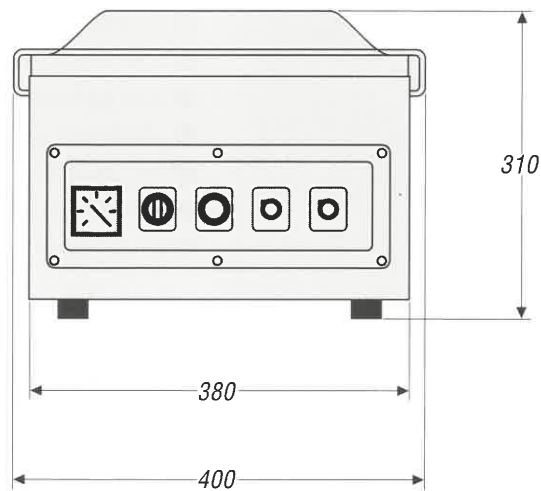

RÖSCHERMATIC · Typ OSNAVAC 5

RÖSCHERMATIC · Type OSNAVAC 5

<i>Kammermaß:</i>	395x420x150 mm
<i>nutzbares Kammermaß:</i>	375x380x150 mm
<i>Schweißschienenlänge:</i>	375 mm
<i>Außenabmessung:</i>	455x590x360 mm
<i>Gewicht:</i>	64 kg
<i>Stromanschluß:</i>	230/400 V, 50 Hz (3Ph/N/PE)
<i>Anschlußwert:</i>	1,0 kW
<small>Kabel 3 m lang mit CEE-Stecker, 5polig, 16 A</small>	
Sonderausstattung:	Trenndrahtschweißung
	Sonderspannungen

<i>chamber dimensions:</i>	395x420x150 mm
<i>effective chamber dimensions:</i>	375x380x150 mm
<i>length of sealing bar:</i>	375 mm
<i>external dimensions:</i>	455x590x360 mm
<i>net weight:</i>	64 kg
<i>voltage:</i>	230/400 V, 50 cycles (3 Ph/N/GRD)
<i>connected load:</i>	1,0 kW
<small>cable of 3 m length with 5-pole CEE-plug, 16 A</small>	
Special Outfit:	cut off wire
	special voltages

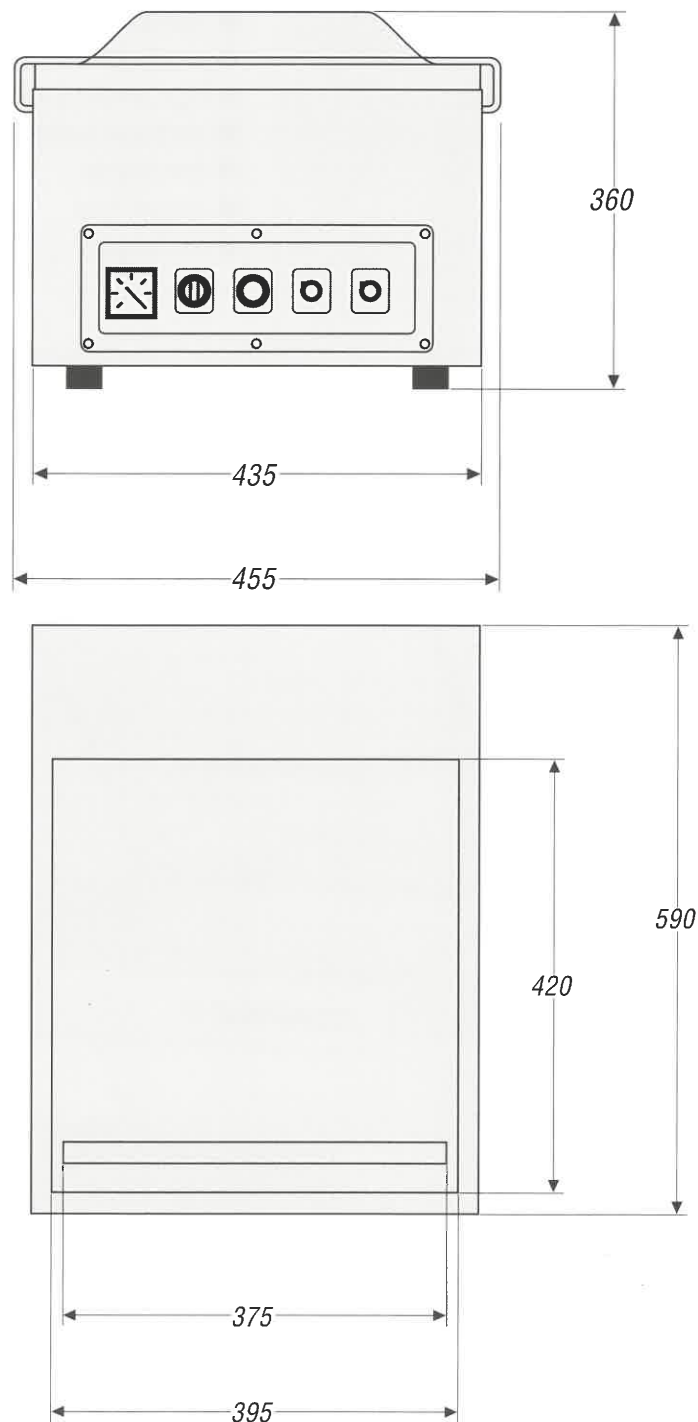

RÖSCHERMATIC · Typ OSNAVAC 19

RÖSCHERMATIC · Type OSNAVAC 19

Kammermaß:	500x560x180 mm
nutzbares Kammermaß:	480x510x180 mm
Schweißschienenlänge:	480 mm
Außenabmessung:	560x730x950 mm
Gewicht:	116 kg
Stromanschluß:	230/400 V, 50 Hz (3Ph/N/PE)
Anschlußwert:	1,5 kW
<small>Kabel 3 m lang mit CEE-Stecker, 5polig, 16 A</small>	
Sonderausstattung:	Trenndrahtschweißung Sonderspannungen

chamber dimensions:	500x560x180 mm
effective chamber dimensions:	480x510x180 mm
length of sealing bar:	480 mm
external dimensions:	560x730x950 mm
net weight:	116 kg
voltage:	230/400 V, 50 cycles (3 Ph/N/GRD)
connected load:	1,5 kW
<small>cable of 3 m length with 5-pole CEE-plug, 16 A</small>	
Special Outfit:	cut off wire special voltages

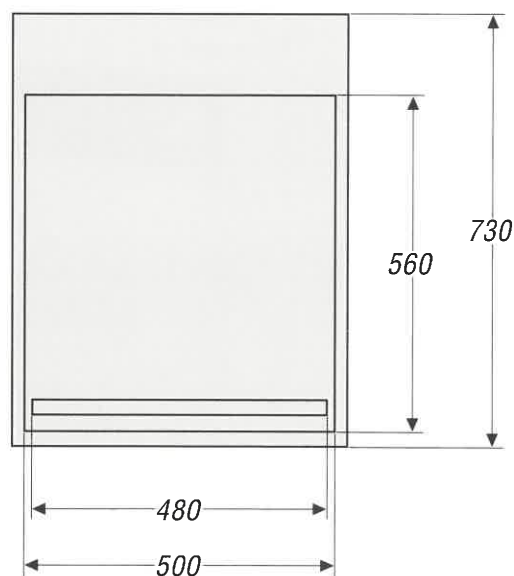
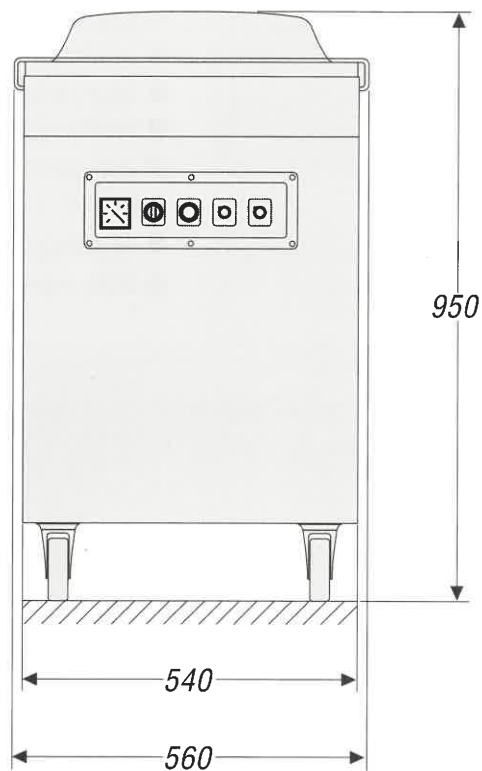

RÖSCHERMATIC - Typ OSNAVAC 21/2

RÖSCHERMATIC - Type OSNAVAC 21/2

Kammermaß:	2 x 460x550x180 mm
nutzbares Kammermaß:	2 x 430x440x180 mm
Schweißschienenlänge:	2 x 430 mm je Kammer
Außenabmessung:	1060x720x1020 mm
Gewicht:	205 kg
Stromanschluß:	230/400 V, 50 Hz (3Ph/N/PE)
Anschlußwert:	1,9 kW
<small>Kabel 3 m lang mit CEE-Stecker, 5polig, 16 A</small>	
Sonderausstattung:	Trenndrahtschweißung Sonderspannungen

chamber dimensions:	2 x 460x550x180 mm
effective chamber dimensions:	2 x 430x440x180 mm
length of sealing bar:	2 x 430 mm per chamber
external dimensions:	1060x720x1020 mm
net weight:	205 kg
voltage:	230/400 V, 50 cycles (3 Ph/N/GRD)
connected load:	1,9 kW
<small>cable of 3 m length with 5-pole CEE-plug, 16 A</small>	
Special Outfit:	cut off wire special voltages

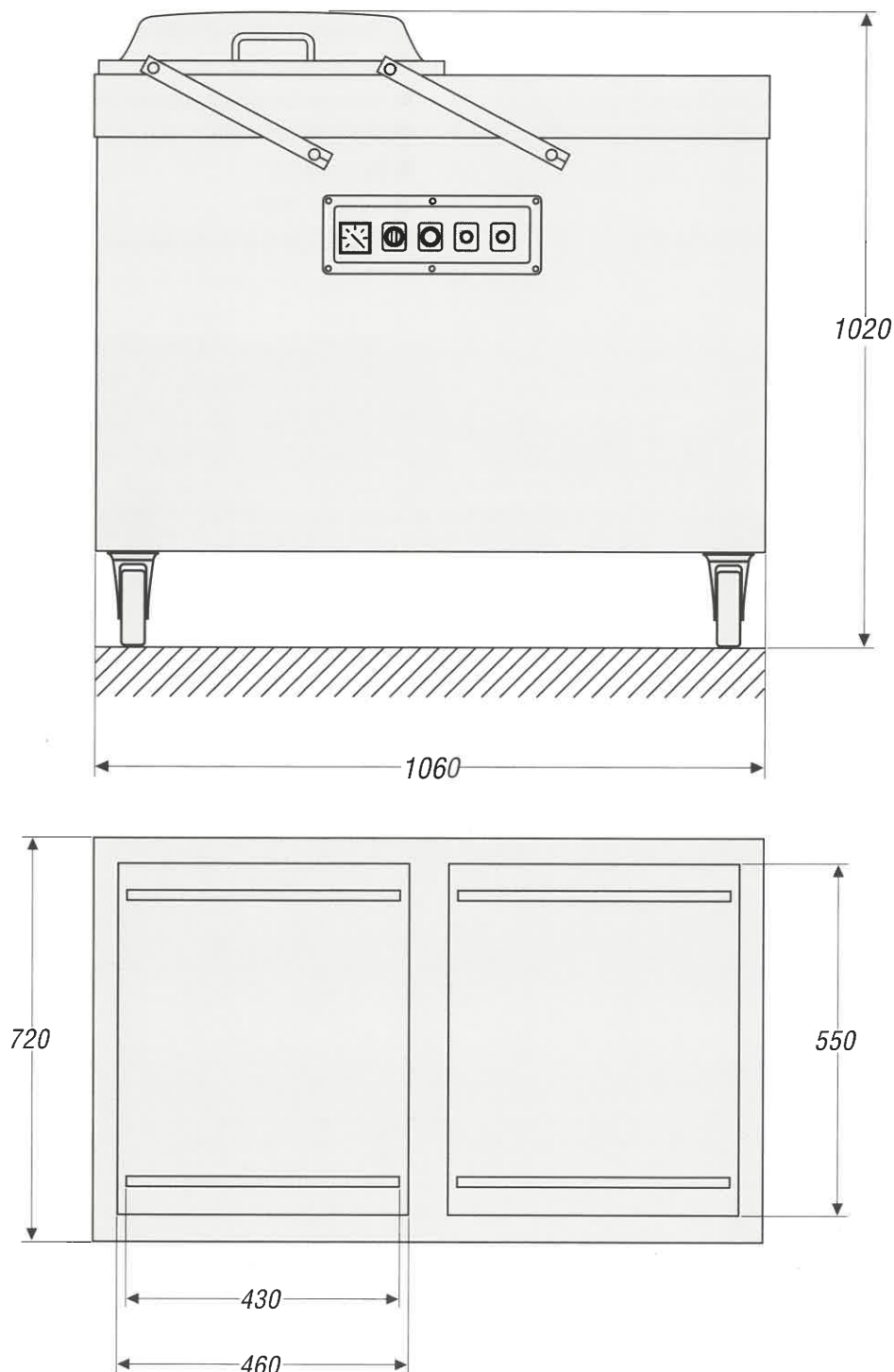

RÖSCHERMATIC · Typ VM-61/2/CL

RÖSCHERMATIC · Type VM-61/2/C L

Kammermaß:	2 x 885x770x200 mm
nutzbare Kammermaße:	2 x 860x640x200 mm
Schweißschielenlänge:	2 x 860 mm pro Kammer
Außenabmessung:	1920x970x1080 mm
Gewicht:	640 kg
Stromanschluß:	230/400 V, 50 Hz (3 Ph/N/PE)
Anschlußwert:	6,2 kW
<small>Kabel 3 m lang mit CEE-Stecker, 5polig, 32 A</small>	
Sonderausstattung:	Sonderspannungen Oben- und Unterschweißung (1 Naht = 5 mm)

chamber dimensions:	2 x 885x770x200 mm
effective chamber dimensions:	2 x 860x640x200 mm
length of sealing bar:	2 x 860 mm per chamber
external dimensions:	1920x970x1080 mm
net weight:	640 kg
voltage:	230/400 V, 50 cycles (3 Ph/N/GRD)
connected load:	6,2 kW
<small>cable of 3 m length with 5-pole CEE-plug, 32 A</small>	
Special Outfit:	special voltages top and bottom sealing (one 5 mm seam)

